



# XEDA-1021-GXRS.0

English	Technical data
01 Power	2.2 kW   7506 BTU/h
02 Frequency	50 / 60 Hz
03 Gas nominal heat input	40 kW   136480 BTU/h
06 Power supply cable type	H07RN-F
07 Voltage Power cable section Circuit breaker	220-240V ~1PH+PE 3G x 1,5 mm <sup>2</sup> 16 A I1 9.5 A In 9.5 A
08 Cable   Plug	✓   Schuko
09 RCD / GFCI	F
11 Water pressure	150-1000 kPa   22-145 psi
12 Water max. consumption (steam)	NaN l/h @ 200 kPa   NaN gal/h @ 29 psi
13 Cavity dimensions (w x d x h)	716 x 724 x 930 mm 28-3/16" x 28-1/2" x 36-5/8"
14 Max. food load	90 kg   198 lbs
15 Max. temperature	300 °C   572 °F
16 IP protection class	X5
17 Data connection	Wifi 2,4 GHz, Wifi 5 GHz
18 Communication protocol	WPA - Personal, WPA 2 - Personal

Italiano
01 Potenza
02 Frequenza
03 Potenza termica nominale gas
06 Tipo cavo alimentazione
07 Tensione Sezione cavi alimentazione Magnetotermico
08 Cavo   Spina
09 RCD / GFCI
11 Pressione acqua
12 Consumo max acqua (vapore)
13 Dimensioni camera cottura (l x p x h)
14 Max. peso pieno carico
15 Temperatura max.
16 Grado protezione IP
17 Data connection
18 Protocollo di comunicazione

Espanol
01 Potencia
02 Frecuencia
03 Potencia térmica nominal de gas
06 Tipo de cable de alimentación
07 Voltaje Sección del cable de alimentación Disyuntor
08 Cable   Enchufe
09 RCD / GFCI
11 Presión del agua
12 Consumo máximo de agua (vapor)
13 Dimensión de la cavidad (w x d x h)
14 Carga máxima de alimentos
15 Temperatura máxima
16 Grado de protección IP
17 Data connection
18 Protocolo de comunicación

Français
01 Puissance électrique
02 Fréquence
03 Puissance calorifique nominale du gaz
06 Type de câble d'alimentation
07 Tension Section câbles d'alimentation Disjoncteur
08 Câble   Prise
09 RCD / GFCI
11 Pression de l'eau
12 Consommation max. d'eau (vapeur)
13 Dimension de la cavité (l x p x h)
14 Charge max. des aliments
15 Température max.
16 Niveau de protection IP
17 Data connection
18 Protocole de communication

Deutsch
01 Elektrische Leistung
02 Frequenz
03 Nennwärmeleistung Gas
06 Stromkabel Typ
07 Spannung Stromkabel Teil Sicherung
08 Leitung   Stecker
09 RCD / GFCI
11 Wasserdruck
12 Maximaler Wasserverbrauch bei Damfbetrieb
13 Abmessungen des Hohlraums (B x T x H)
14 Maximale Beladungskapazität
15 Maximale Temperatur
16 IP-Schutzart
17 Data connection
18 Kommunikations-Protokoll

Terms and conditions of installations - Observe all local specific standard and regulations for installation and operations.



Русский
01 Мощность
02 Частота
03 Номинальная газовая потребляемая мощность
06 Тип силового кабеля
07 Напряжение Сечение силового кабеля Токовый автомат
08 Кабель   Вилка
09 RCD / GFCI
11 Давление воды
12 Максимальное потребление воды (пар)
13 Габариты камеры (ш x г x в)
14 Максимальная загрузка
15 Максимальная температура
16 Класс защиты IP
17 Data connection
18 Протокол передачи данных

中文
01 功率
02 频率
03 燃气额定热输入
06 电源电缆类型
07 电压 电源电缆截面 断路器
08 电缆和插头
09 RCD / GFCI
11 水压
12 最大水消耗 (蒸汽)
13 腔室尺寸 (宽 x 深 x 高)
14 最大食物负荷
15 最高温度
16 IP保护等级
17 Data connection
18 通讯协议

Português
01 Potência
02 Frequência
03 Potência térmica nominal gas
06 Tipo de cabo de alimentação
07 Tensão Seção de cabos de alimentação Disjuntor
08 Cabo   Plugue
09 RCD / GFCI
11 Pressão da água
12 Max. consumo de água (vapor)
13 Dimensão de cavidade (c x l x a)
14 Max. capacidade de alimento
15 Max. temperatura
16 Grau de proteção IP
17 Data connection
18 Protocolo de comunicação

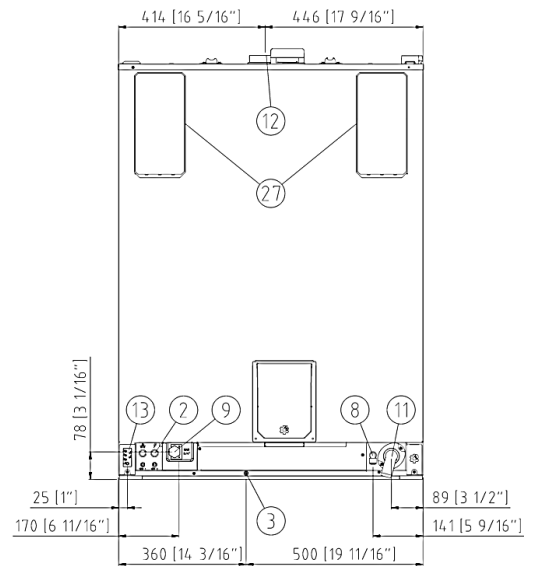
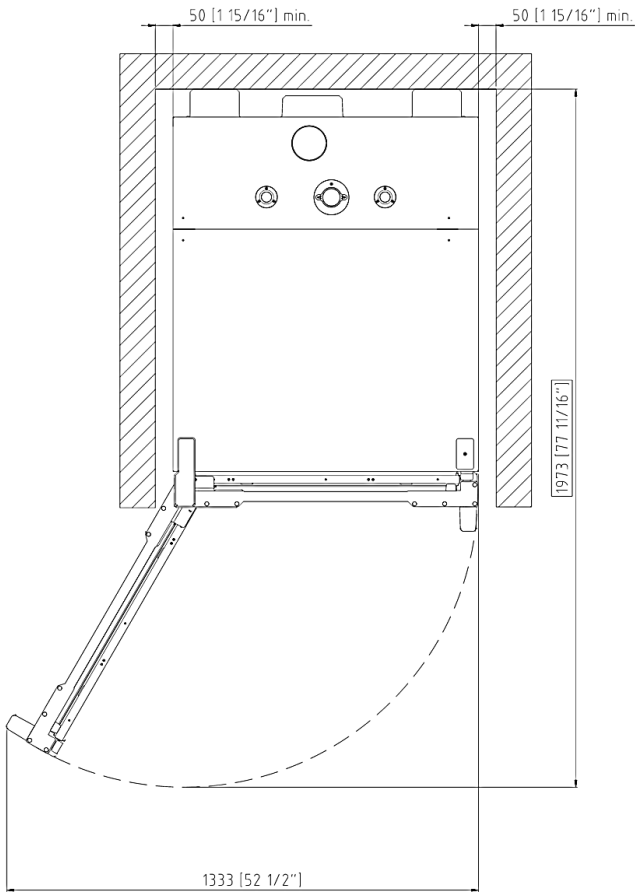
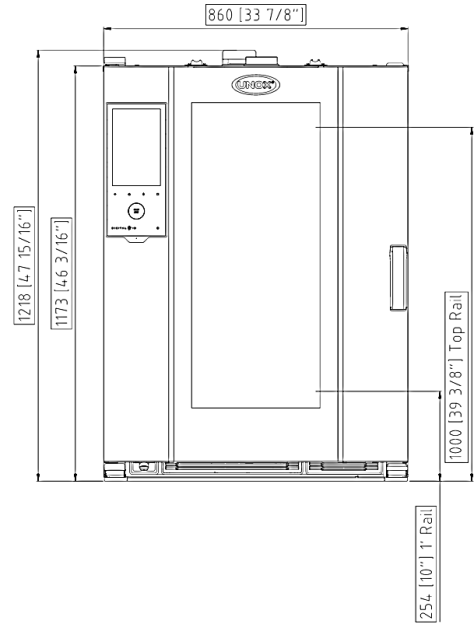
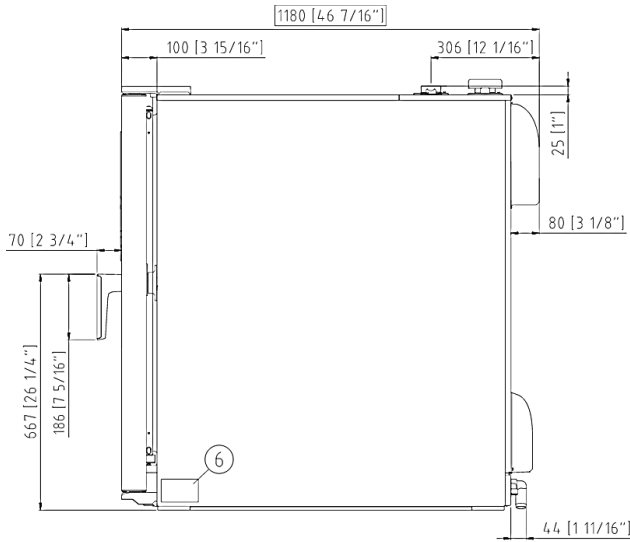

	English	Italiano	Español	Français	Deutsch
02	Electrical connection	Allacciamento elettrico	Conexión eléctrica	Raccordement électrique	Elektrischer Anschluss
08	Water connection	Allacciamento idrico	Conexión de agua	Raccordement à l'eau	Wasseranschluss
09	Gas connection	Allacciamento gas	Conexión de gas	Raccordement au gaz	Gasanschluss
11	Water drain	Scarico acqua	Desagüe del agua	Evacuation	Abflussrohr
12	Smoke exhaust	Scarico fumi	Salida de humos	Aspiration des fumées	Abluftrohr
13	Accessories connection	Collegamento accessori	Conexión de accesorios	Connexion des accessoires	Anschluss des Zubehörs
30	Combustion fumes	Fumi di combustione	Gases de combustión	Fumées de combustion	Abgasse
31	Air inlet	Ingresso aria	Entrada de aire	Entrée d'air	Lufteinlass
	Русский	中文	Português		
02	Электрическое подключение	电源连接	Conexão elétrica		
08	Подключение к воде	水连接	Conexão hídrica		
09	Подключение к газу	燃气连接	Conexão gás		
11	Выход воды	排水	Saída de água		
12	Выход газов	排烟	Saída de fumaça		
13	Подключение аксессуаров	配件连接	Conexão de acessórios		
30	Продукты горения	燃烧烟雾	Fumaça de combustão		
31	Воздухозаборник	空气入口	Entrada de ar		

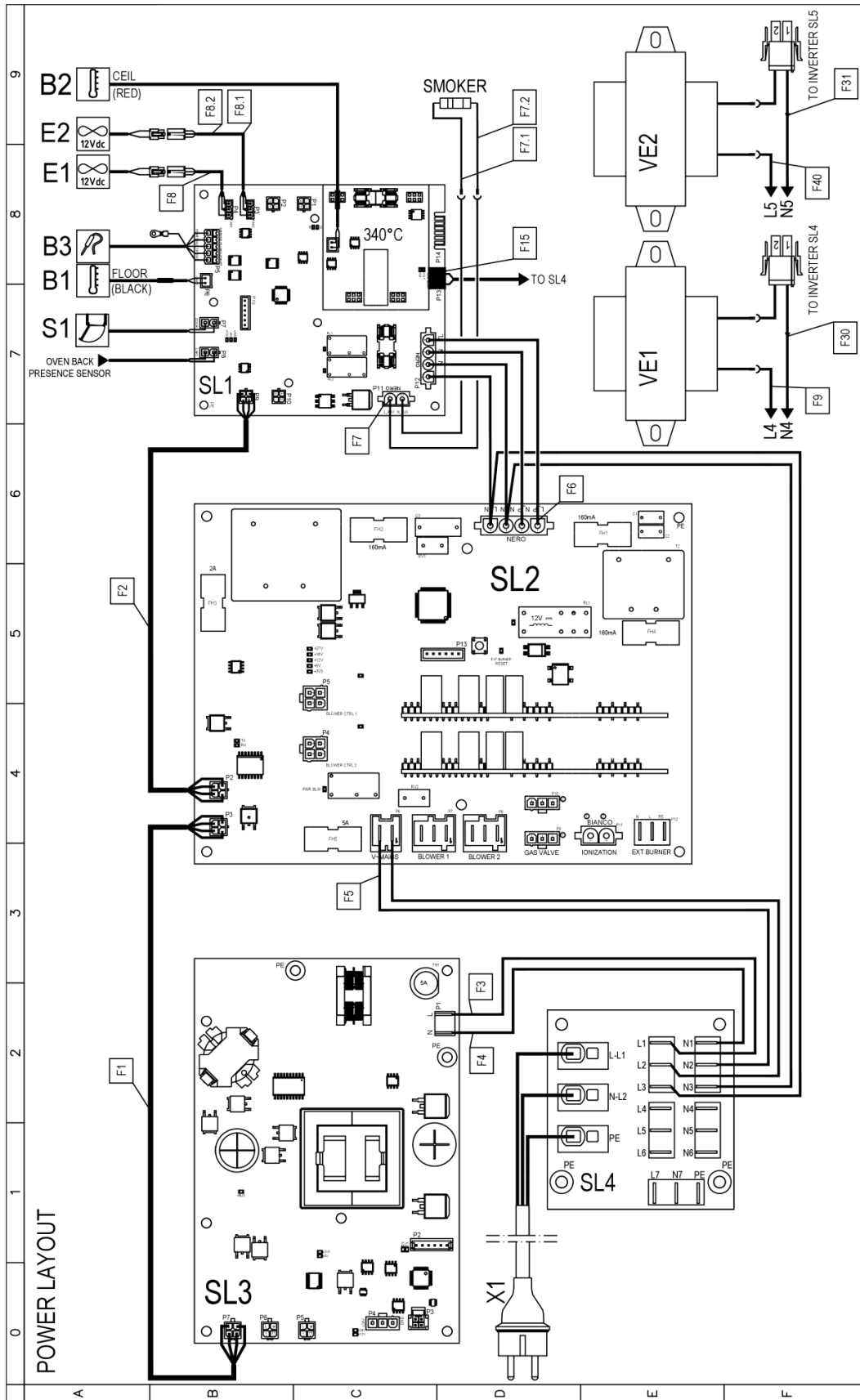

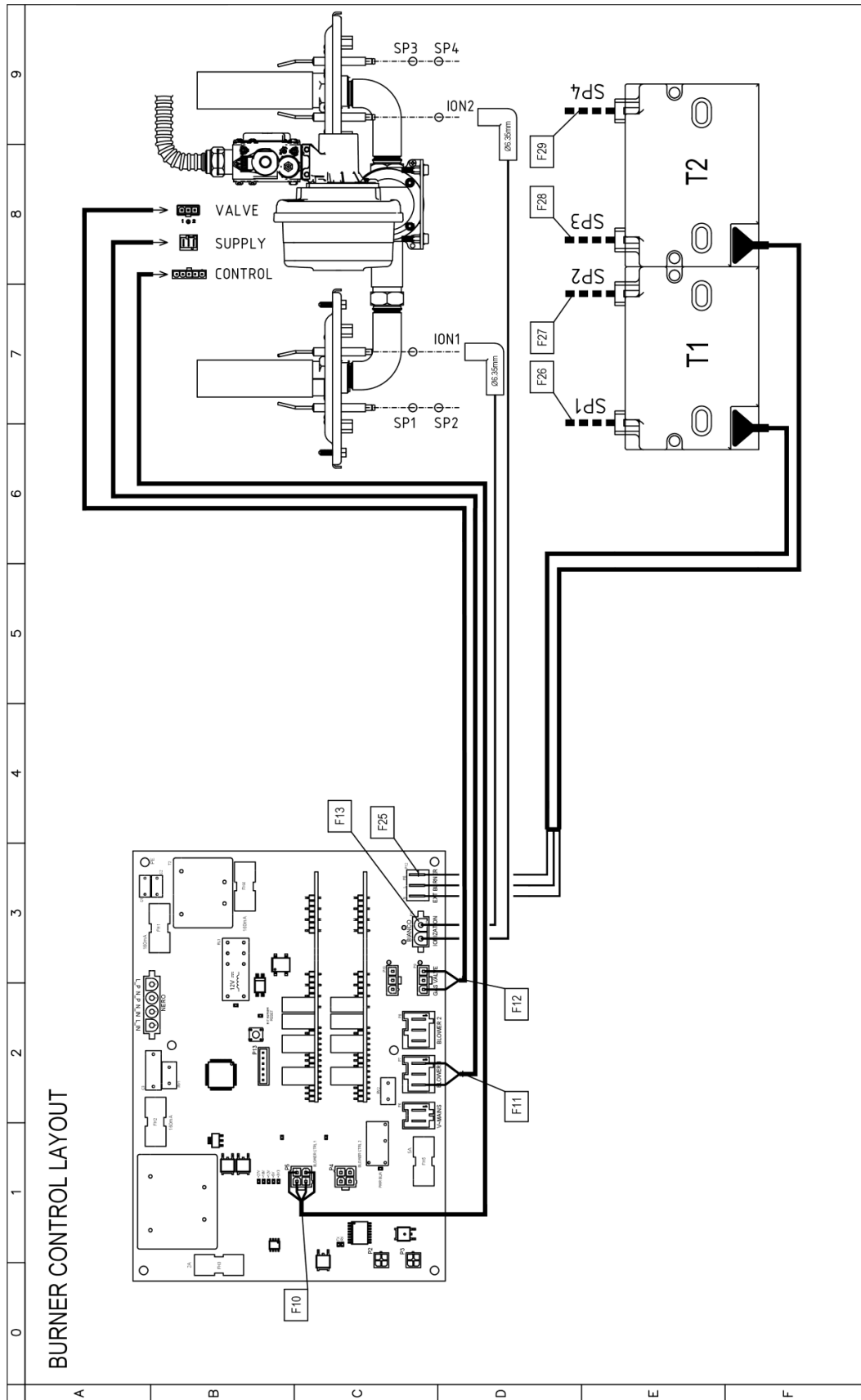

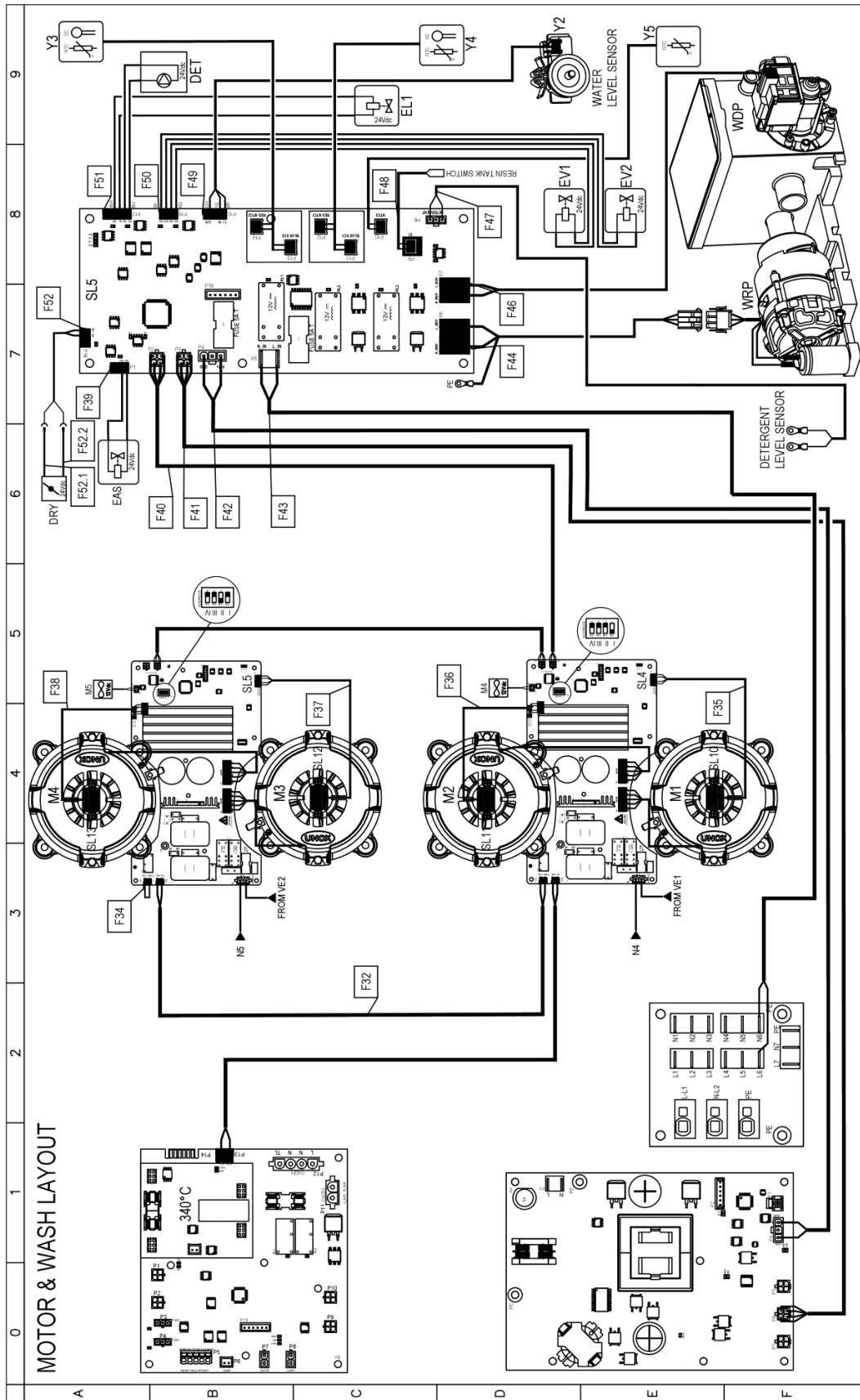

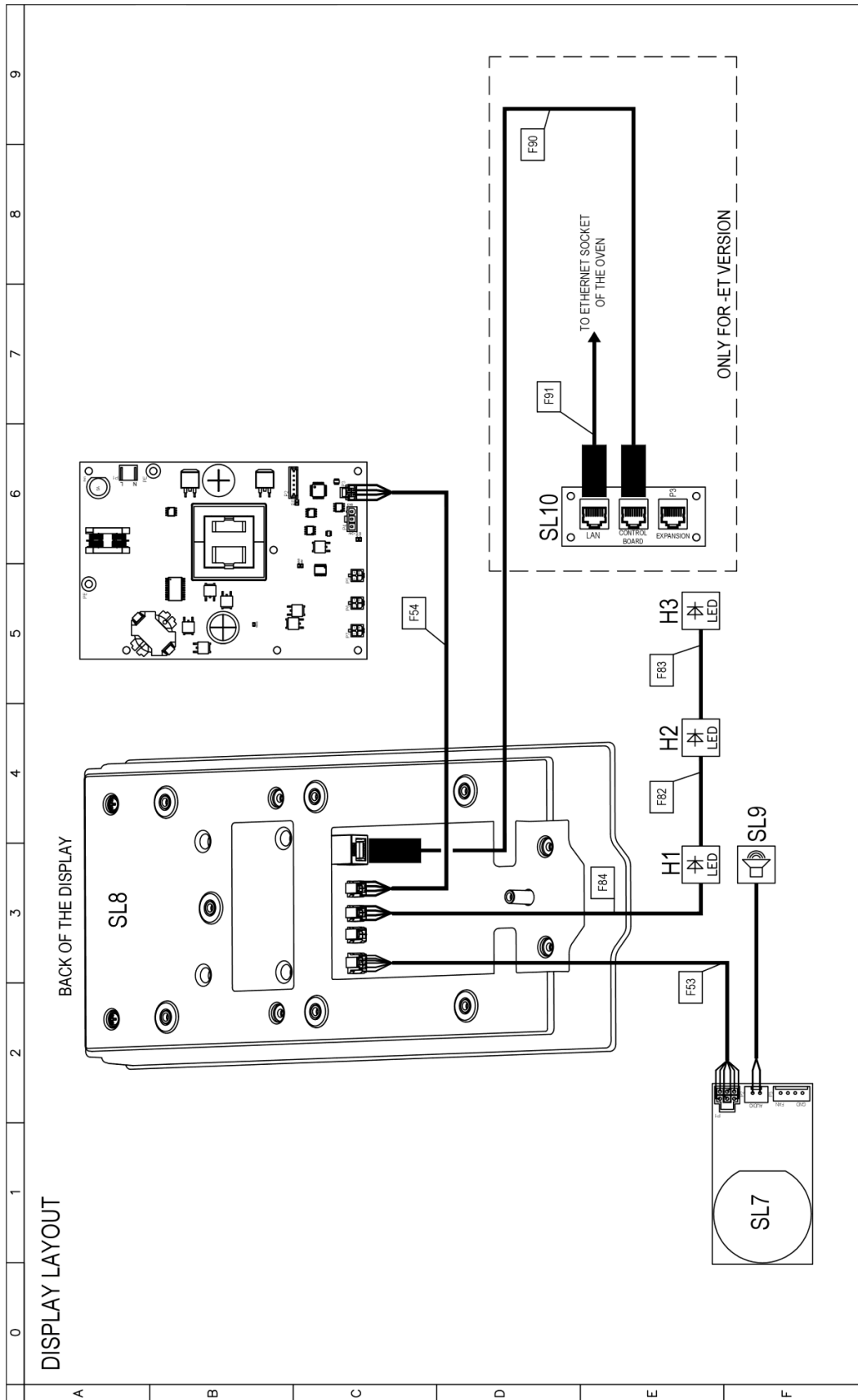

	0	1	2	3	4	5	6	7	8	9
A										
B										
C										
D										
E										
F										

Stigle	ITALIANO	ENGLISH	FRANCAIS	ESPAÑOL	DEUTSCH
SL1	SCHEDA POTENZA	POWER CARD	CARTE DE PUISSANCE	TARJETA POTENCIA	POWERPLATINE
SL2	SCHEDA POTENZA	POWER CARD	CARTE DE PUISSANCE	TARJETA POTENCIA	POWERPLATINE
SL3	SCHEDA POTENZA	POWER CARD	CARTE DE PUISSANCE	TARJETA POTENCIA	POWERPLATINE
SL4	MORSETTIERA	TERMINAL BLOCK	BORNIER	CONECTOR	KLEMMLEISTE
SL10	BRIDGE ETHERNET	BRIDGE ETHERNET	BRIDGE ETHERNET	BRIDGE ETHERNET	BRIDGE ETHERNET
VE1,VE2	REATTORE DI LINEA	LINE REACTOR	REACTEUR DE LIGNE	REACTOR DE LINEA	LEITUNGSREAKTOR
X1	CAVO ALIMENTAZIONE +-SCHUKO	POWER CORD +-SCHUKO	EPINIERE ET SCHUKO	CABLE Y ENCHUFE SCHUKO	KABEL UND SCHUKO-STECKER
DET	POMPA 24Vdc	PUMP 24Vdc	POMPE 24Vdc	BOMBA 24Vdc	PUMPE 24Vdc
DRY	DRY MAXY 24Vdc	DRY MAXY 24Vdc	DRY MAXY 24Vdc	DRY MAXY 24Vdc	DRY MAXY 24Vdc
EAS,EL1,EV1,EV2	ELETTROVALVOLA ACQUA 24Vdc	WATER SOLENOID VALVE 24Vdc	ELECTROVANNE EAU 24Vdc	ELECTROVALVULA 24Vdc	ELEKTROVENTIL 24Vdc
SL5	SCHEDA POTENZA	POWER CARD	CARTE DE PUISSANCE	TARJETA POTENCIA	POWERPLATINE
Y3,Y4	SONDA CONDUCTIMETRO	CONDUCTIVITY PROBE	SONDE DE CONDUCTIVITE	SONDA DE CONDUCTIVIDAD	LEITFAHIGKEITSSONDE
Y5	SONDA TEMPERATURA	TEMPERATURE PROBE	SONDE DE TEMPERATURE	SONDA TEMPERATURA	TEMPERATURFUHLER
B1,B2	SONDA CAMERA	TEMPERATURE PROBE	SONDE DE CHAMBRE	SONDA CAMARA	GARRAUMTEMPERATURFUHLER
B3	SONDA AL CUORE	CORE PROBE	SONDE A COEUR	SONDA CORAZON	KERNTTEMPERATURFUHLER
E1,E2	VENTOIA RAFFREDDAMENTO 12V	COOLING FAN 12V	TURBINE DE REFROIDISSEMENT 12V	TURBINA DE REFRIGERACION 12V	LUFTER 12V
H1,H2,H3	LUCE CAMERA	OVEN LIGHT	ECLAIRAGE DE CHAMBRE	LUZ CAMARA	BELEUCHTUNG
M1,M2,M3,M4,M4	MOTORE	MOTOR	MOTEUR	MOTOR	MOTOR
M4,M4,M5	VENTOIA RAFFREDDAMENTO 12V	COOLING FAN 12V	TURBINE DE REFROIDISSEMENT 12V	TURBINA DE REFRIGERACION 12V	LUFTER 12V
S1	MICRO INTERRUPTORE PORTA	DOOR MICROSWITCH	MICROINTERRUPTEUR DE PORTE	MICROINTERRUPTOR PUERTA	TURKONTAKTSCHALTER
SL4,SL5	SCHEDA POTENZA	POWER CARD	CARTE DE PUISSANCE	TARJETA POTENCIA	POWERPLATINE
SL7	SCHEDA POTENZA	POWER CARD	CARTE DE PUISSANCE	TARJETA POTENCIA	POWERPLATINE
SL8	SCHEDA CONTROLLO	CONTROL BOARD	CARTE DE CONTROLE	TARJETA DE CONTROL	KONTROLL PLATINE
SL9	ALTOPARLANTE	SPEAKER	CONFRENCIER	ALTAVOZ	LAUTSPRECHER
SL10,SL11,SL12,SL13	SENSORE VELOCITA MOTORE	MOTOR SPEED SENSOR	CAPTEUR DE VITESSE MOTEUR	SENSOR DE VELOCIDAD MOTOR	GESCHWINDIGKEITSSENSOR
T1,T2	TRASFORMATORE D'ACCENSIONE	IGNITION TRANSFORMER	TRANSFORMATEUR D'ALLUMAGE	TRASFORMADOR D'IGNICION	ZUNDRASFORMATOR
WDP,WRP	POMPA	PUMP	POMPE	BOMBA	PUMPE
Y2	SENSORE LIVELLO	WATER LEVEL	CAPTEUR DE NIVEAU	SENSORE DE NIVEL	FULLSTANDSSENSOR



<b>TAB100111A</b>  <b>Installation type:</b> <b>A3- Free Single unit</b> <b>B13- Unit with draught diverter</b> <b>B23- Single or Stacked units under hood</b>							 Throttle [turns from closed position]	 Throttle [Δ turns from G20 setting]	Gas fumes test 1 (MAX)		Gas fumes test 2 (MIN)	
Oven Model	Tray type	Gas type	Nominal GAS power [kW]	Nominal GAS power [MJ/h]	Inlet pressure [mbar]	Ø GAS Valve orifice [mm]			CO <sub>2</sub> [% v/v]	CO [ppm]	CO <sub>2</sub> [% v/v]	CO [ppm]
XEDA-0611-GXxS	GN1/1	G110	13,5	48,6	5 - 40 mbar	-	21,5	11	4,00 ≤ CO <sub>2</sub> ≤ 5,00		3,50 ≤ CO <sub>2</sub> ≤ 5,00	
		G20	15	54	5 - 40 mbar	-	10,5	-	9,30 ≤ CO <sub>2</sub> ≤ 9,90		8,50 ≤ CO <sub>2</sub> ≤ 9,90	
		G25	15	54	5 - 40 mbar	-	12,25	1,75	9,40 ≤ CO <sub>2</sub> ≤ 10,00		8,20 ≤ CO <sub>2</sub> ≤ 10,00	
		G25.1	15	54	5 - 40 mbar	-	11,5	1	9,50 ≤ CO <sub>2</sub> ≤ 10,40	<30	8,50 ≤ CO <sub>2</sub> ≤ 10,40	<30
		G25.3	15	54	5 - 40 mbar	-	11,5	1	9,50 ≤ CO <sub>2</sub> ≤ 10,10		8,30 ≤ CO <sub>2</sub> ≤ 10,10	
		G30	15	54	5 - 40 mbar	5,5	8	-2,5	11,00 ≤ CO <sub>2</sub> ≤ 12,50		9,30 ≤ CO <sub>2</sub> ≤ 12,50	
		G31	15	54	5 - 40 mbar	5,5	9,5	-1	10,50 ≤ CO <sub>2</sub> ≤ 11,50		9,00 ≤ CO <sub>2</sub> ≤ 11,50	
XEDA-1011-GXxS	GN1/1	G110	20	72	5 - 40 mbar	-	20,5	10,5	4,00 ≤ CO <sub>2</sub> ≤ 5,00		3,50 ≤ CO <sub>2</sub> ≤ 5,00	
		G20	25	90	5 - 40 mbar	-	10	-	9,30 ≤ CO <sub>2</sub> ≤ 9,90		8,50 ≤ CO <sub>2</sub> ≤ 9,90	
		G25	24	86,4	5 - 40 mbar	-	12,25	2,25	9,40 ≤ CO <sub>2</sub> ≤ 10,00		8,20 ≤ CO <sub>2</sub> ≤ 10,00	
		G25.1	23	82,8	5 - 40 mbar	-	12,25	2,25	9,50 ≤ CO <sub>2</sub> ≤ 10,40	<30	8,50 ≤ CO <sub>2</sub> ≤ 10,40	<30
		G25.3	25	90	5 - 40 mbar	-	12,75	2,75	9,50 ≤ CO <sub>2</sub> ≤ 10,10		8,30 ≤ CO <sub>2</sub> ≤ 10,10	
		G30	25	90	5 - 40 mbar	5,5	7,75	-2,25	11,00 ≤ CO <sub>2</sub> ≤ 12,50		9,30 ≤ CO <sub>2</sub> ≤ 12,50	
		G31	25	90	5 - 40 mbar	5,5	9,5	-0,5	10,50 ≤ CO <sub>2</sub> ≤ 11,50		9,00 ≤ CO <sub>2</sub> ≤ 11,50	
XEDA-0621-GXxS	GN2/1	G110										
		G20	27	97,2	5 - 40 mbar	-	10,5	-	9,30 ≤ CO <sub>2</sub> ≤ 9,90		8,50 ≤ CO <sub>2</sub> ≤ 9,90	
		G25	25	90	5 - 40 mbar	-	12,5	2	9,40 ≤ CO <sub>2</sub> ≤ 10,00		8,20 ≤ CO <sub>2</sub> ≤ 10,00	
		G25.1	23	82,8	5 - 40 mbar	-	12	1,5	9,50 ≤ CO <sub>2</sub> ≤ 10,40	<30	8,50 ≤ CO <sub>2</sub> ≤ 10,40	<30
		G25.3	26	93,6	5 - 40 mbar	-	12	1,5	9,50 ≤ CO <sub>2</sub> ≤ 10,10		8,30 ≤ CO <sub>2</sub> ≤ 10,10	
		G30	27	97,2	5 - 40 mbar	5,5	8,5	-2	11,00 ≤ CO <sub>2</sub> ≤ 12,50		9,30 ≤ CO <sub>2</sub> ≤ 12,50	
		G31	27	97,2	5 - 40 mbar	5,5	9,5	-1	10,50 ≤ CO <sub>2</sub> ≤ 11,50		9,00 ≤ CO <sub>2</sub> ≤ 11,50	
XEDA-1021-GXxS	GN2/1	G110										
		G20	40	144	5 - 40 mbar	-	10,5	-	9,30 ≤ CO <sub>2</sub> ≤ 9,90		8,50 ≤ CO <sub>2</sub> ≤ 9,90	
		G25	36	129,6	5 - 40 mbar	-	12,25	1,75	9,40 ≤ CO <sub>2</sub> ≤ 10,00		8,20 ≤ CO <sub>2</sub> ≤ 10,00	
		G25.1	36	129,6	5 - 40 mbar	-	12,25	1,75	9,50 ≤ CO <sub>2</sub> ≤ 10,40	<30	8,50 ≤ CO <sub>2</sub> ≤ 10,40	<30
		G25.3	37,5	135	5 - 40 mbar	-	12	1,5	9,50 ≤ CO <sub>2</sub> ≤ 10,10		8,30 ≤ CO <sub>2</sub> ≤ 10,10	
		G30	40	144	5 - 40 mbar	5,5	8	-2,5	11,00 ≤ CO <sub>2</sub> ≤ 12,50		9,30 ≤ CO <sub>2</sub> ≤ 12,50	
		G31	40	144	5 - 40 mbar	5,5	8,75	-1,75	10,50 ≤ CO <sub>2</sub> ≤ 11,50		9,00 ≤ CO <sub>2</sub> ≤ 11,50	